



ELECTRO-CHEMICAL DEVICES

### Features

- Panel Mounted System Plumb and Play Design
- Automatic pH Compensation
- Automatic Flow Control
- C22 Analyzer Capability

### Benefits

- Complete System, Easy Installation, Ready to Use
- No Expensive Reagents
- Eliminates Pressure Regulators and Rotameters
- Dual Measurements  
24VDC or 110/220 VAC Power  
XY Graphical Plot  
Optional PID Control Output



Model FCA-22  
*Free Chlorine Analyzer*

## Description

The FCA-22 is a panel mounted, ready to use Free Chlorine Analyzer. It is designed to monitor free chlorine in drinking water, rinse water, cooling water or other fresh water samples from 0.05 – 20 ppm  $\text{Cl}_2$ . The FCA-22 features a plug and play design that incorporates a flow control device, a pH sensor, a chlorine sensor and the C22 analyzer/controller conveniently mounted on a PVC panel. Connect the sample and drain lines, connect the power and outputs and it is ready to use. Calibration is accomplished by DPD comparison.

Free chlorine exists in solution as a pH dependent ratio of hypochlorous acid (~100% at pH 5) and hypochlorite ion (~100% at pH 10). The Free Chlorine Sensor measures only the hypochlorous acid component of the free chlorine and the analyzer calculates the balance using either the

measured pH or a user defined fixed value. The use of the pH sensor provides accurate compensation for samples between pH 6 and pH 9.5 and eliminates the need for an expensive sample conditioning system to control the pH of the solution. The C22 allows either parameter to be graphically displayed with user defined ranges allowing easy trend analysis.

Amperometric chlorine sensors are flow sensitive, the minimum required flow by the sensor is 0.5 ft/sec, above this value the output is virtually flow independent. A "Constant head" Flow control Device (CFD) maintains the optimum flow by the sensor over a wide range of incoming sample flow rates. The minimum flow required for the CFD is 10 gal/hr and the maximum flow is 80 gal/hr with the sample going to drain at atmospheric pressure.

# FCA-22 Free Chlorine Analyzer

## Specifications

### Sensor and Flow Train

#### Sensor

Polarographic, Gold/Silver, PTFE membrane

#### Measurement Range

Chlorine: 0.05 to 20 ppm

pH: 0 to 14 pH

#### Operating Temperature

0° C to 50° C (32° F to 122° F)

#### Min/Max Flow

38 L/hr to 300 L/hr (10 gal/hr to 80 gal/hr)

#### Wetted Materials

PVC, PP, PVDF, PTFE, Glass, 316 SS

#### Process Connections

Input ¼" barb fitting, Drain ¾" barb fitting

#### Response Time

T90 in 2 minutes

#### Electrolyte Life

Up to 12 months

### C22 Analyzer

#### Measurements

Chlorine: 0.05 to 20 ppm

pH: 0 to 14 pH

Temperature: 0° C to 100° C (32° F to 212° F)

#### pH Compensation

pH 5 - 10

#### Display

2.5" X 1.75" backlit LCD, 4 lines for Text & Graphical

#### Enclosure

NEMA 4X, LxWxD: 5.7" x 5.7" x 7

#### Outputs

4-20 mA for Free Chlorine; 800 ohm@24 VDC

Optional PID output and additional 4-20 mA outputs

#### Input Power

110/220 VAC @ 50/60 Hz

Optional 24 VDC (12 to 50 VDC) @ 0.25A

#### Alarm Relay Ratings

(2) SPDT 230 VAC/5A or 30 VDC/5A resistive max.

Optionally up to (8) Relays

Part No.	Model and Product Description
1290020-1	Free Chlorine Analyzer (FCA-22), complete, with automatic pH compensation
1290021-1	Free Chlorine Analyzer (FCA-22), complete, with manual pH compensation

Part No.	Spare Parts and Accessories Description
1390908	Free Chlorine Sensor, Complete
1000238	Membrane Replacement Kit with electrolyte
1408060	PHS10 Sensor, Complete
2005145.VIT	Replacement pH Cartridge
1406711.ECD	PHD10, PVC bodied disposable pH sensor
1000236-1	Chlorine Flow Cell
3501048-1	pH Flow Cell
1000237-1	Constant Flow Device

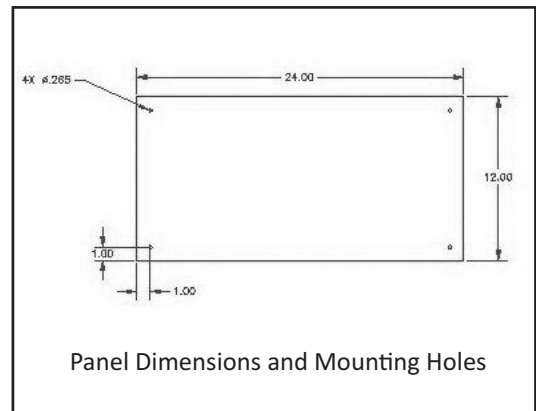

Specifications subject to change without notice.

### Represented by:

#### Electro-Chemical Devices

1681 Kettering

Irvine, California, USA 92614

Phone: +1-949-336-6060

+1-800-729-1333

Fax: +1-949-336-6064

email: sales@ecdi.com

web: www.ecdi.com



FCA22 H0409